

# W114

GATE  
OPENER  
KIT

# The **power** to ensure seamless movement.

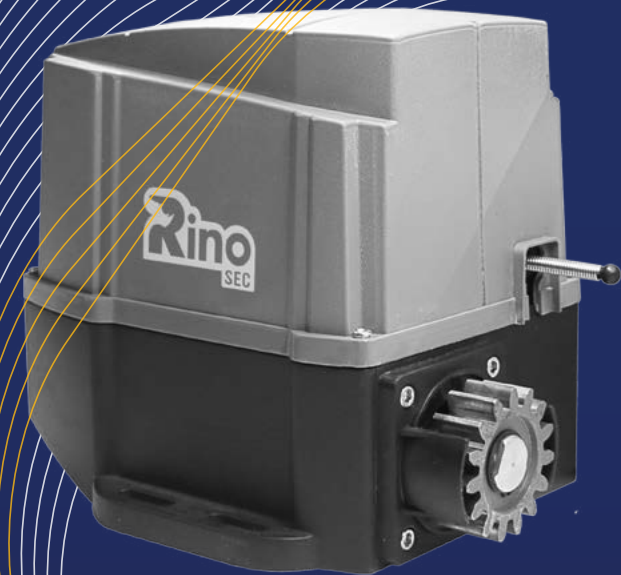

Quick and easy to install and use, this actuator is ideal for any industrial context. Safe and reliable, they can be integrated into the BMS system. this electromechanical motor support sliding gates with maximum weight of 1000 kg and 2000 kg.

**Rino**  
ALL YOUR SECURITY NEEDS! SEC



## AUTOMATIONS MOTOR FOR SLIDING GATES up to 1000KG



- 230 VAC
- 230 Vac geared motor with built-in control unit and limit switch.
  - Irreversible electromechanical geared motor with easy access release from left side.
  - Easy and quick to install due to compact size and installation dimensions

- Worm protected by a scraper ring and stainless steel stem, suitable for use in dusty and sandy environments or where there are aggressive atmospheric agents.
- W114 - 1000 version for industrial huge doors and confident installation dimensions

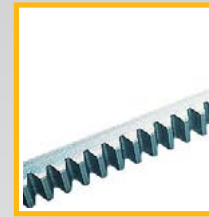

RI  
M4 galvanized rack



VARIO 12/24V  
Photocell



VITO 220V  
Blinker



RA  
M4 plastic rack



ARO  
Accessories



ARO access  
keypad



VANEO  
Remote



[www.rinosec.com](http://www.rinosec.com) [info@rinosec.com](mailto:info@rinosec.com)

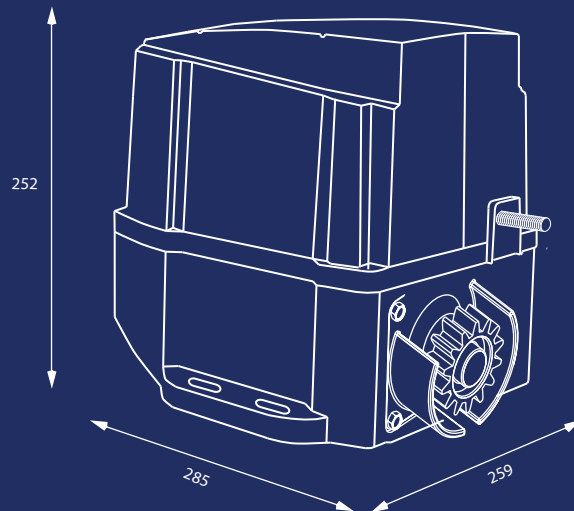

Model	W114
Power supply	230V~ / 50Hz
Max absorption	1,7A
Power absorbed	370W
Capacitor	8µF
Max thrust	1000N
Opening speed reg.	11m/min
limit switche	electromechanical
Max gate weight	1000kg
Dutycycle	%60
Operating temperature	-20°C /+55°C
Degree of protection	IP44
Weight (kg)	8.250



## AUTOMATIONS MOTOR FOR SLIDING GATES up to 2000KG



- 230 VAC
- 230 Vac geared motor with built-in control unit and limit switch.
  - Irreversible electromechanical geared motor with easy access release from left side.
  - Easy and quick to install due to compact size and installation dimensions

- Worm protected by a scraper ring and stainless steel stem, suitable for use in dusty and sandy environments or where there are aggressive atmospheric agents.
- W114 - 2000 version for industrial huge doors and confident installation dimensions

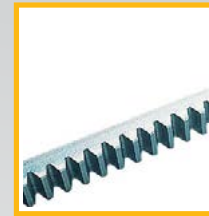

RI  
M4 galvanized rack



VARIO 12/24V  
Photocell



VITO 220V  
Blinker



RA  
M4 plastic rack



ARO  
Accessories



ARO access  
keypad



VANEO  
Remote



[www.rinosec.com](http://www.rinosec.com) [info@rinosec.com](mailto:info@rinosec.com)

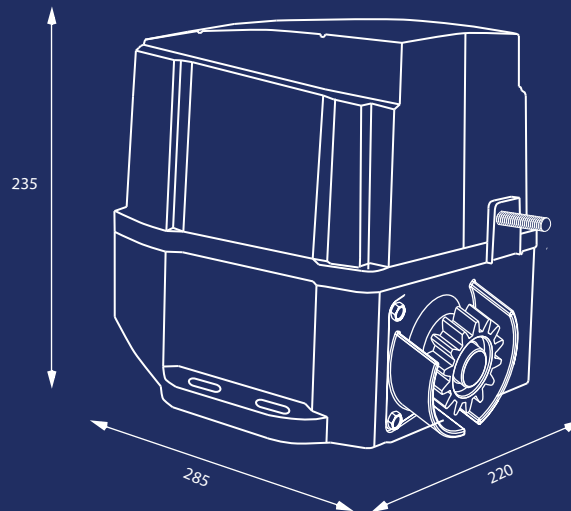

Model	W114
Power supply	230V~ / 50Hz
Max absorption	1,9A
Power absorbed	450W
Capacitor	8µF
Max thrust	2000N
Opening speed reg.	11m/min
limit switche	electromechanical
Max gate weight	2000kg
Dutycycle	%60
Operating temperature	-20°C /+55°C
Degree of protection	IP44
Weight (kg)	8.850